



PLANT, TOOL & GRAB LORRY HIRE

anglianplantLtd

EQUIPMENT & SERVICES 2016

t: 01692 536997 e: hire@anglianplant.com
www.anglianplant.com





CALL NOW
TO HIRE
01692 536997

ANGLIAN PLANT LIMITED

A BRIEF INSIGHT

Anglian Plant Limited was incorporated in 2009 from the roots of a company that specialised in machinery trading. We recognised an opening for a plant hire company that offers an experience that's not only straight forward but supported with a high level of customer service.

Now an established company we continue to offer our customers large and small alike a friendly service with a family feeling. We strive to offer quality equipment at competitive rates backed by reliable logistics and responsive engineers.



Search: Anglian Plant Ltd

If you cannot see what you are looking for in this guide please call us, its likely we can source it for you.

INDEX

Excavators	6 - 10
Wheel Diggers/Backhoes	11
Site Dumpers	12 - 13
Telescopic Handlers	14 - 16
Rollers	18-19
Concrete Crusher	20-21
Powered Access	23 - 27
Bowers	28
Lighting	29
Small Tools	32
Mobile Welfare	34-35
How To Hire	36
Calendar	37
Contact Details	38
Credit Account Form	39



1 Tonne Micro Excavator

Width 710mm
Expanding to 1100mm
Height 2209mm
reducing to tbc

- (A) 196°
- (B) 3145.0 mm
- (C) 3093.0 mm
- (D) 1374.0 mm
- (E) 196.0 mm
- (F) 230.0 mm
- (G) 1899.0 mm
- (H) 2685.0 mm
- (I) 1818.0 mm
- (J) 1383.0 mm
- (K) 1820.0 mm

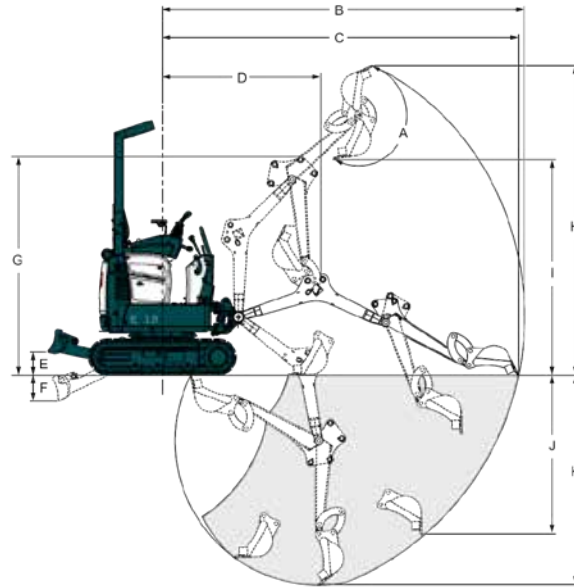

3 Tonne Mini Excavator

Width 1550mm
Height 2537mm

- (A) 4010mm
- (B) 2783mm
- (C*) 2672mm
- (C) 2461mm
- (D) 1832mm
- (E) 4313 mm
- (F) 4484 mm

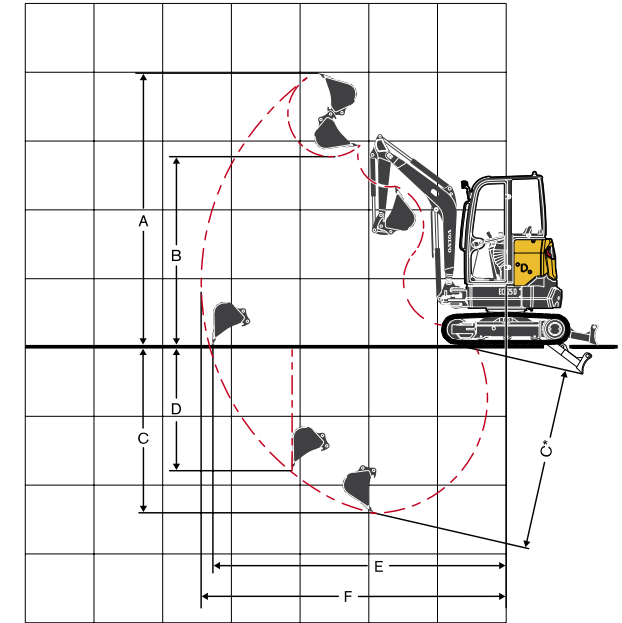

1.6 Tonne Mini Excavator

Width 980mm
Expanding to 1330mm
Height 2171mm

- (A) 196°
- (B) 4146.0 mm
- (B*) 4319.0 mm
- (C) 4101.0 mm
- (C*) 4276.0 mm
- (D) 1576.0 mm
- (D*) 1586.0 mm
- (E) 308.0 mm
- (F) 368.0 mm
- (G) 2564.0 mm
- (H) 3616.0 mm
- (H*) 3743.0 mm
- (I) 2529.0 mm
- (I*) 2656.0 mm
- (J) 2139.0 mm
- (J*) 2310.0 mm
- (K) 2422.0 mm
- (K*) 2602.0 mm

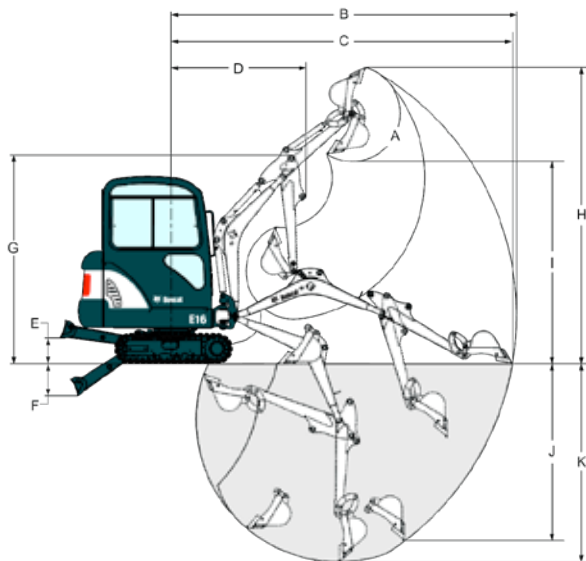

5 Tonne Midi Excavator

Width 1920mm
Height 2570mm

- (A) 5400 mm
- (B) 3809 mm
- (C) 3400 mm
- (C*) 3659mm
- (D) 2417 mm
- (E) 5771 mm
- (F) 5908mm

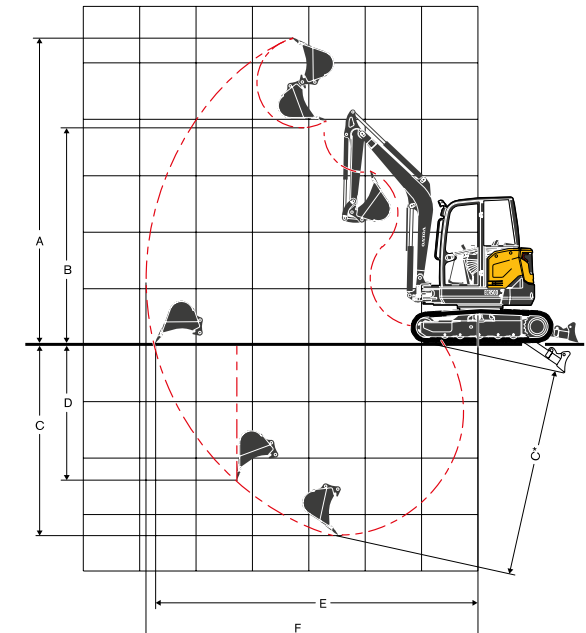

Width 2300mm
Height 2715mm

- (A) 6790 mm
- (B) 6800 mm
- (C) 4130 mm
- (D) 3750 mm
- (E) 2820 mm
- (F) 6790 mm
- (G) 4960 mm
- (H) 2560 mm

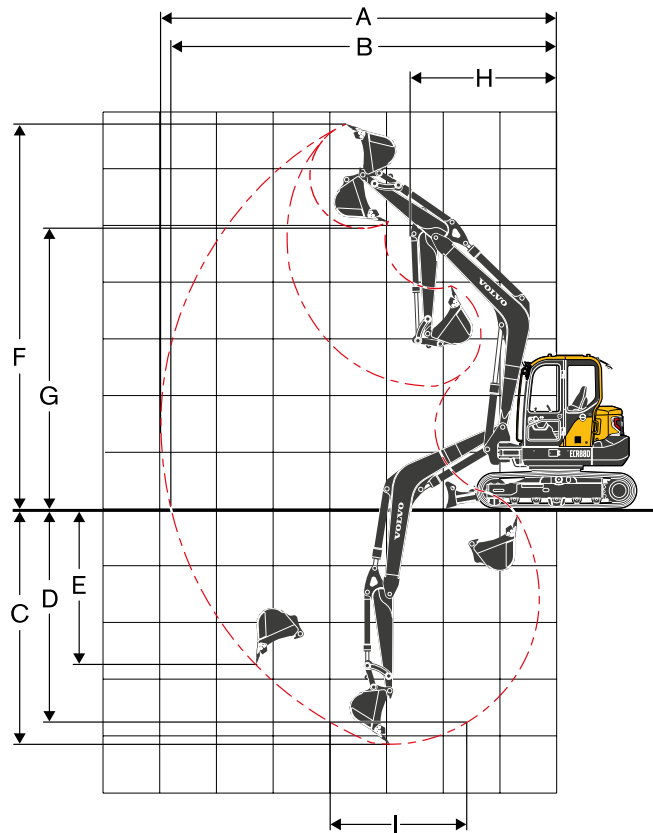

- Dig Depth 5850mm
- Reach at Ground Level 8650mm
- Dump Height 6330mm
- Height 860mm
- Width 2700mm
- Tail Swing Radius 2330mm
- Ground Clearance 440mm
- Track Length 3750mm
- Track Pad Width 700mm



14 Tonne Excavator reduced tail swing

- Dig Depth 5990mm
- Reach at Ground Level 8630mm
- Dump Height 7230mm
- Height 2900mm
- Width 2700mm
- Tailswing Radius 1480mm
- Ground Clearance 440mm
- Track Length 3820mm
- Track Pad Width 700mm





- Dig Depth 6730mm
- Reach at Ground Level 9820mm
- Dump Height 6790mm
- Height 3100mm
- Width 3495mm
- Tail Swing Radius 2840mm
- Ground Clearance 660mm
- Track Length 4440mm
- Track Pad Width 700mm



- Weight 8070kg
- Width 2350mm
- Height 2910mm
- Dig depth 5970mm

0.5 Tonne Tracked Dumper

- Machine weight 475kg
- Carrying capacity 500kg
- Clearance tipping 1.45m
- Machine length 1.7m
- Machine width 0.69m



3 Tonne Swivel Tip Dumper

- Unladen weight 2160kg
- Width 1650mm
- Height (Rops Up) 3092mm
- Height (Rops Down) 1965mm
- Maximum tipping height 735mm
- Skip capacity 1640Ltr
- Length 3935mm
- Maximum safe load 3000kg



1 Tonne High Tip Dumper

- Unladen weight 1295kg
- Width: Normal Wheels 1115mm
- Height (Rops Up) 2860mm
- Height (Rops Down) 1773mm
- Maximum tipping height 1573mm
- Skip capacity 500Ltr
- Length 3032mm
- Maximum safe load 1000kg



6 Tonne Swivel Tip Dumper

- Unladen weight 4340kg
- Width 2280mm
- Height (Rops Up) 3300mm
- Height (Rops Down) 2230mm
- Maximum tipping height 1100mm
- Skip capacity 3150Ltr
- Length 4750mm
- Maximum safe load 6000kg



4m Lift Telescopic Handler

- Lift Capacity 2 Tonnes
- Max Lift height 4 Metres
- Width 1560mm
- Length 3380mm
- Height 1970mm



8m Lift Telescopic Handler

- Lift Capacity 5 Tonnes
- Max Lift Height 8.1 Metres
- Width 2420mm
- Length 5270mm
- Height 2590mm



7m Lift Telescopic Handler

- Lift Capacity 3.1 Tonnes
- Max Lift Height 7 Metres
- Width 2230mm
- Length 4990mm
- Height 2490mm



9.5m Lift Telescopic Handler

- Lift Capacity 3.5 Tonnes
- Max Lift Height 9.5 Metres
- Width 2290mm
- Length 4990mm
- Height 2490mm



10.5m Lift Telescopic Handler

- Lift Capacity 3.3 Tonnes
- Max Lift Height 10.2 Metres
- Width 2290mm
- Length 5380mm
- Height 2490mm



14m Lift Telescopic Handler

- Lift Capacity 4 Tonnes
- Max Lift Height 13.8 Metres
- Width 2350mm
- Length 6250mm
- Height 2590mm



17m Lift Telescopic Handler

- Lift Capacity 4 Tonnes
- Max Lift Height 16.7 Metres
- Width 2440mm
- Length 6360mm
- Height 2690mm



GRAB LORRY HIRE

Anglian Plant Limited operate a fleet of 6 and 8 wheel tipper grab lorries. We undertake spot hires, contract hires and day rate hires for muck away and aggregate deliveries.

01692 536997 • hire@anglianplant.com

www.anglianplant.com

Anglian Plant Ltd, Beeches Farm, Crowgate Street,
Tunstead, Norwich, Norfolk NR12 8RF

Single Drum 55cm Vibrating Roller

- Drum Width 560mm
- Operating Weight 161kg
- Fuel Petrol



80cm Twin Drum Vibrating Roller

- Drum Width 800mm
- Operating Weight 1620kg



Single Drum 71cm Vibrating Roller

- Drum Width 710mm
- Operating Weight 512kg
- Fuel Diesel
- C/W Trailer & optional Breaker



120cm Twin Drum Vibrating Roller

- Drum Width 1200mm
- Operating Weight 2700kg



3 Tonne Concrete Crusher

- Operating Weight 3200kg
- Jaw Width 450mm x 280mm
- Output Size 20mm – 50mm



20 Tonne Compact Concrete Crusher



Portable Mini Screener

Portable mini screener suitable for use with either our 3 or 20 tonne crushers.

- Engine: 9.5 HP (7.1 kW) Diesel
- Transport Height: 9' 9" (2983mm)
- Transport Width: 7' 7" (2320mm)
- Transport Length: 17' 10" (5430mm)
- Weight: 7,000 lbs (3,200 kg) estimated



Weighing only 20 tonnes this compact crusher can be transported on a standard low loader offering cheaper transport costs than larger units. It still boasts a respectable output of up to 120 tonnes per hour despite its compact size.

- Operating Weight 19500kg
- Jaw Width 760mm x 600mm
- Loading Height 2600mm
- Discharge Height 2720mm
- Over Conveyor Magnetic Separator

One operator using radio control for crushing and manoeuvring operations
Dust suppression using water spray inside crusher and at outlet and belts

EXCAVATOR BREAKERS & ATTACHMENTS

CONCRETE BREAKERS
TO SUIT 1-22 TONNE EXCAVATORS

TRENCHING UNITS
TO SUIT 3 TONNE EXCAVATORS

EARTH DRILLS/AUGERS
TO SUIT 1.5-8 TONNE EXCAVATORS

RIDDLE BUCKETS
TO SUIT 5-22 TONNE EXCAVATORS

DEMOLITION GRAPPLES
TO SUIT 14-22 TONNE EXCAVATORS

PALLET FORKS
TO SUIT 5-8 TONNE EXCAVATORS

12 Metre Reach Towable Access Platform

- Working Height 12.33m
- Working Outreach 5m
- Safe Working Load 200kg
- Operating Weight 1195kg

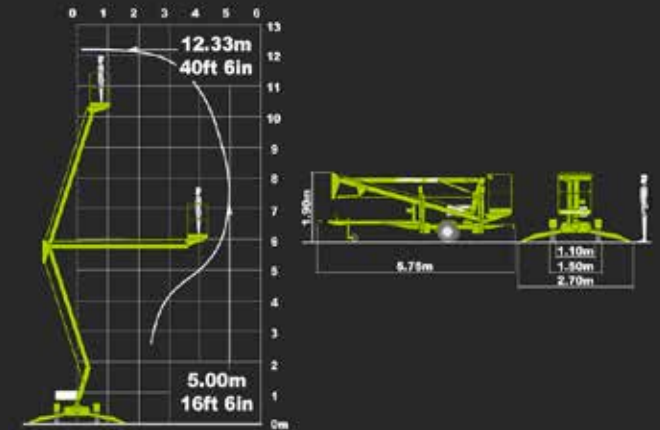

17 Metre Reach Towable Access Platform

- Working Height 17.1m
- Working Outreach 8.7m
- Safe Working Load 200kg
- Operating Weight 1900kg

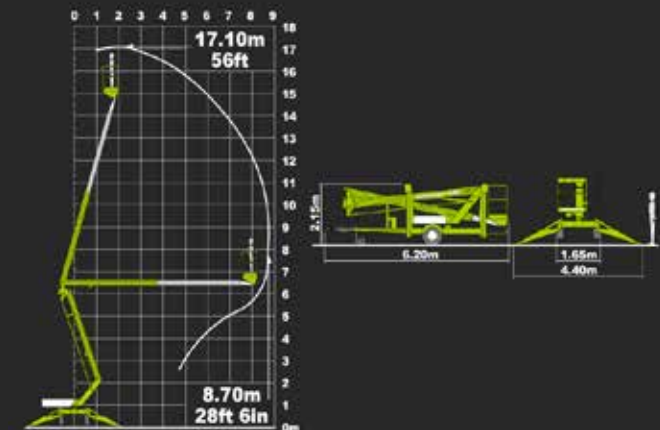

8 metre Electric Scissor Lift



- Working Height 8.2m
- Lifting Capacity 350kg
- Platform Size 3.22 x 0.8m

12 metre Electric Scissor Lift



- Working Height 12.15m
- Lifting Capacity 450kg
- Platform Size 3.7 x 1.54m

10 metre Rough Terrain Diesel Scissor Lift



- Working Height 10.15m
- Lifting Capacity 565kg
- Platform Size 3.7 x 1.54m

10 metre Electric Scissor Lift



- Working Height 10.15m
- Lifting Capacity 450kg
- Platform Size 3.22 x 1.2m

14 metre Electric Scissor Lift



- Working Height 13.8m
- Lifting Capacity 350kg
- Platform Size 3.22 x 1.22m

12 metre Rough Terrain Diesel Scissor Lift



- Working Height 12m
- Lifting Capacity 300kg
- Platform Size 3.22 x 1.2m

12 Metre Self Propelled Access Platform

- Working Height 12.2m
- Working Outreach 6.1m
- Safe Working Load 200kg
- Operating Weight 3330kg

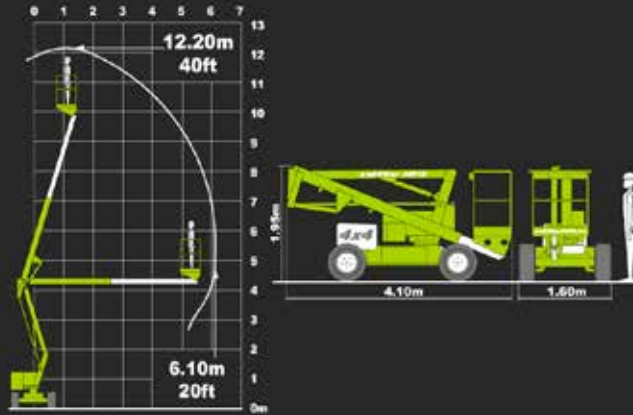

16 Metre Self Propelled Access Platform

- Working Height 15.97m
- Working Outreach 7.49m
- Safe Working Load 227kg
- Operating Weight 6078kg



21 Metre Self Propelled Access Platform

- Working Height 20.8m
- Working Outreach 12.8m
- Safe Working Load 225kg
- Operating Weight 6500kg

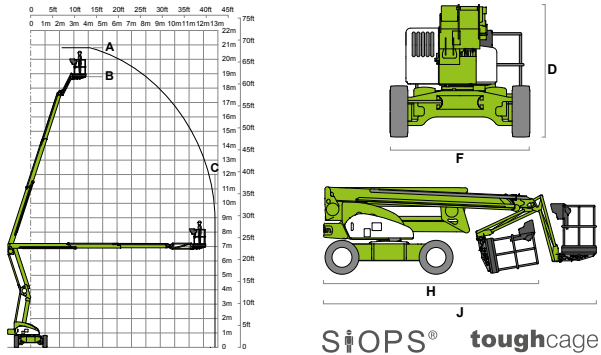

20 Metre Self Propelled Access Platform

- Working Height 20.39m
- Working Outreach 11.05m
- Safe Working Load 227kg
- Operating Weight 10215kg





BOWSERS

- Road Tow, Site Tow and Static Fuel Bowers in Various Sizes
- Towable Water Bowers

9m Towable Lighting Tower



- Maximum Height 9m
- Run Time 60 Hours
- Flood Lights 4 x 1000w
- Weight 1115kg

ANGLIAN PLANT ARE
PROUD TO BE SUPPLIED BY
THE FOLLOWING DEALERS:



Bobcat Mini Excavators, Skidsteers & Telescopic Handlers



Mobile Welfare



OPERATED PLANT HIRE

All plant listed in this catalogue can be supplied not only on a self drive basis but also complete with a CPCS card holding operator.

01692 536997 • hire@anolianplant.com
www.anolianplant.com

Anolian Plant Ltd, Beeches Farm, Crowgate Street, Tunstead, Norwich, Norfolk NR12 8RF



TOOLS

As well as our range of plant we offer a comprehensive selection of tools such as:

Compaction Plates • Trench Rammers • Water Pumps
 Disc Cutters • Alloy Scaffold Tower • Site Mixers • Pokers
 Laser Levels • Cat Scanners • Floor Saws • Hydraulic breaker packs

LOOKING TO BUY?

We sell plant too, we can offer a varied selection of one owner well maintained machines for sale at any time.

Contact us with your requirements.
 Joe@anglianplant.com 01692 536997

6 Man Towable Welfare Unit



- Net Weight: 1740kg
- Gross weight: 1800kg
- Diesel Tank: 58 litres
- Fresh Water: 25 litres
- Waste Capacity: 25 litres
- Toilet Capacity: 225 litres
- Drinking Water: 25 litres
- Unit Length: 3.60 metres
- Unit Width: 2.30 metres
- Unit Height: 2.37 metres
- Towing Length: 5.20 metres
- T ● owing Height: 2.69 metres

1. Table
2. Strip Light
3. Bench Seating
4. Worktop
5. Microwave
6. 240v Consumer Unit
7. Drinking Water
8. Soap Dispenser
9. Forearm sink
10. Hotwash
11. Towel Dispenser
12. 240v Heater
13. Window Inc. Security Shutter
14. Coat Hooks
15. Diesel Generator
16. Drying Room
17. Generator/Drying Room Door
18. Toilet Door
19. Canteen Door
20. Tubular Heater
21. WC
22. P.I.R Light

12 Man Towable Welfare Unit

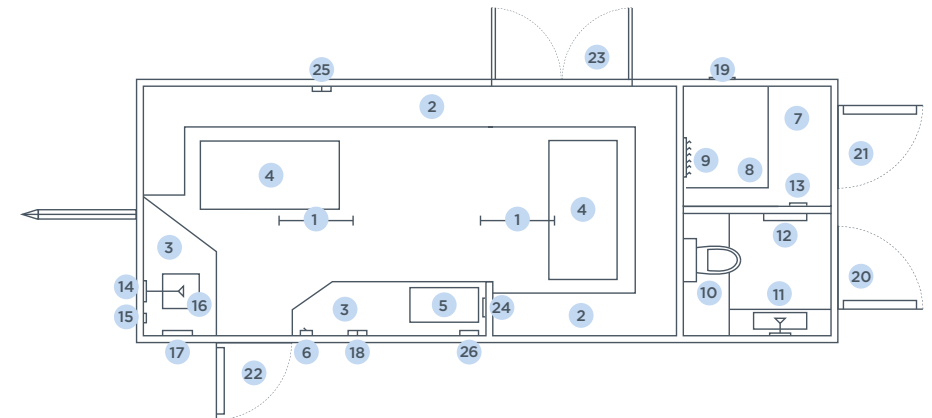

1. Strip Light
2. Bench Seating
3. Worktop
4. Table
5. Microwave
6. Light switch
7. Drying Room
8. Generator
9. Coat Hooks
10. WC
11. Forearm sink and Hotwash
12. P.I.R Light
13. Light Switch
14. Hotwash
15. Soap Dispenser
16. Forearm Sink
17. Towel Dispenser
18. Double socket
19. Vents
20. Toilet Door
21. Generator and Drying Room Door
22. Personnel Door
23. Window Inc. Security Shutter
24. Generator Remote Start
25. CO Monitor
26. Consumer unit

- Net Weight: 1900kg
- Gross weight: 2000kg
- Diesel Tank: 58 litres
- Fresh Water: 25 litres
- Waste Capacity: 25 litres
- Toilet Capacity: 225 litres
- Drinking Water: 25 litres
- Unit Length: 4.80 metres
- Unit Width: 2.30 metres
- Unit Height: 2.37 metres
- Towing Length: 5.88 metres
- T ● owing Height: 2.72 metres

HOW TO HIRE

TERMS

All items are hired under "Construction Plant Hire Association" terms, these can be requested from a member of staff or viewed on our website.

DELIVERY

Please call for delivery charges.

FUEL

Prices quoted exclude fuel. We can supply fuel if required, please contact the office for the current rate.

VAT

All prices quoted exclude VAT at the current rate.

PAYMENT

Non-account holders are required to pay pre-hire inclusive of a deposit and will need to produce ID.

For a credit account download the account form from our website or contact the office and we will send you one. Complete and return and we will process immediately so you can hire straight away.



CALENDAR 2016

JAN 2016

M	T	W	T	F	S	S
				1	2	3
4	5	6	7	8	9	10
11	12	13	14	15	16	17
18	19	20	21	22	23	24
25	26	27	28	29	30	31

FEB 2016

M	T	W	T	F	S	S
1	2	3	4	5	6	7
8	9	10	11	12	13	14
15	16	17	18	19	20	21
22	23	24	25	26	27	28
29						

MAR 2016

M	T	W	T	F	S	S
	1	2	3	4	5	6
7	8	9	10	11	12	13
14	15	16	17	18	19	20
21	22	23	24	25	26	27
28	29	30	31			

APR 2016

M	T	W	T	F	S	S
				1	2	3
4	5	6	7	8	9	10
11	12	13	14	15	16	17
18	19	20	21	22	23	24
25	26	27	28	29	30	

MAY 2016

M	T	W	T	F	S	S
					1	
2	3	4	5	6	7	8
9	10	11	12	13	14	15
16	17	18	19	20	21	22
23	24	25	26	27	28	29
30	31					

JUN 2016

M	T	W	T	F	S	S
	1	2	3	4	5	
6	7	8	9	10	11	12
13	14	15	16	17	18	19
20	21	22	23	24	25	26
27	28	29	30			

JUL 2016

M	T	W	T	F	S	S
				1	2	3
4	5	6	7	8	9	10
11	12	13	14	15	16	17
18	19	20	21	22	23	24
25	26	27	28	29	30	31

AUG 2016

M	T	W	T	F	S	S
1	2	3	4	5	6	7
8	9	10	11	12	13	14
15	16	17	18	19	20	21
22	23	24	25	26	27	28
29	30	31				

SEPT 2016

M	T	W	T	F	S	S
			1	2	3	4
5	6	7	8	9	10	11
12	13	14	15	16	17	18
19	20	21	22	23	24	25
26	27	28	29	30		

OCT 2016

M	T	W	T	F	S	S
					1	2
3	4	5	6	7	8	9
10	11	12	13	14	15	16
17	18	19	20	21	22	23
24	25	26	27	28	29	30
31						

NOV 2016

M	T	W	T	F	S	S
	1	2	3	4	5	6
7	8	9	10	11	12	13
14	15	16	17	18	19	20
21	22	23	24	25	26	27
28	29	30				

DEC 2016

M	T	W	T	F	S	S
			1	2	3	4
5	6	7	8	9	10	11
12	13	14	15	16	17	18
19	20	21	22	23	24	25
26	27	28	29	30	31	

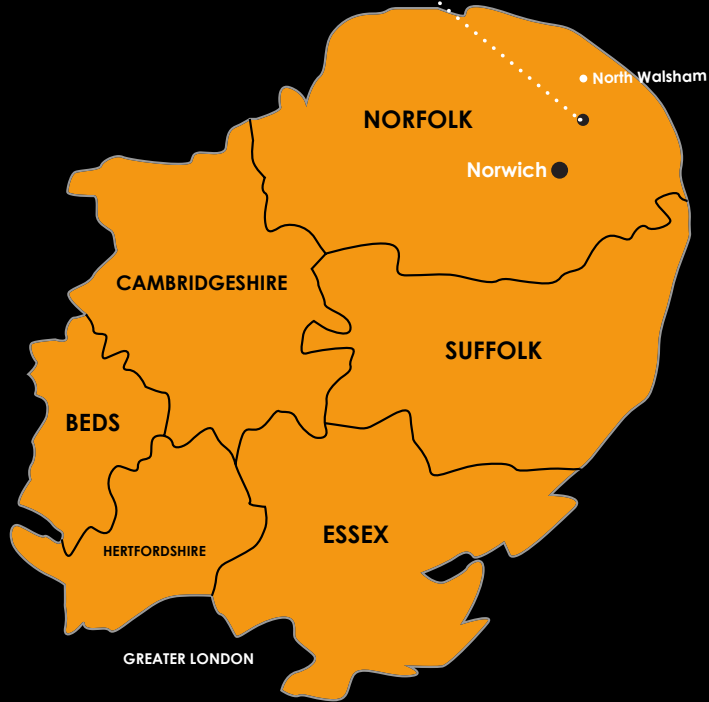

PLANT HIRE THROUGHOUT EAST ANGLIA

Call **01692 536997**
to be put through to the relevant department

Hire Desk - hire@anglianplant.com
Work Shop - stuart@anglianplant.com
Accounts - steph@anglianplant.com
Sales - joe@anglianplant.com

Visit: Beeches Farm, Crowgate Street, Tunstead, Norwich, Norfolk NR12 8RF

www.anglianplant.com

APPLICATION FOR CREDIT ACCOUNT

PLC Limited Company Sole Trader Charity

Company Name:		
Address:		
Postcode:	*Reg No:	VAT No.:
Tel:	Fax:	
Email:		
Contact in Accounts Department:		
*Registered Office Address (If any different from above):		
*Names of proprietors (If non-limited company – please include date of birth and home address)		

TRADE REFERENCES

Company:	Contact Name:
Address:	
Post Code:	Telephone No:
Company:	Contact Name:
Address:	
Post Code:	Telephone No:

I hereby authorise Anglian Plant Limited to obtain references from the above as and when appropriate. I agreed to abide by the terms and conditions as set out by Anglian Plant Limited which include that all invoices are due to be paid within 30 days from the date of invoice and that a purchase order must be given for services rendered.

I declare I have authority to apply for credit limit of £ on behalf of the company.

Signed: _____ Printed Name: _____

Position: _____ Date: _____

FOR OFFICE USE ONLY:

A) Credit safe limit is checked? B) Risk Disk limit is checked? C) Euler grade has been requested?
D) Trade references have been obtained (written or verbal)? E) Application is signed off and credit limit applied by JP?

Please complete in full and return complete with a copy of your hired in plant insurance.

email: steph@anglianplant.com
Post: Anglian Plant Limited, Beeches Farm, Crowgate Street, Norwich, Norfolk, NR12 8RF • 01692 536997 • www.anglianplant.com

*All hires of equipment will be strictly subject to CPA terms and conditions of business. View on website or request a copy.





PLANT, TOOL & GRAB LORRY HIRE

anglianplantLtd

Call Us: **01692 536997**

Email: **hire@anglianplant.com**

Visit: Beeches Farm, Crowgate Street, Tunstead,
Norwich, Norfolk NR12 8RF

www.anglianplant.com